

**67" DUET
CAST IRON
DOUBLE ROLL TOP TUB**

REJUVENATION



L: 67-³/₄"
 W: 31"
 H: 23-¹/₄" (from floor to top of tub)
 18-¹/₂" (from bottom of tub to top of tub)

Water depth: 12-¹/₂" to Over flow
 Slope: 30°



Maximum Gallon Capacity: 55
 Shipping Weight: 570 lbs.
 Empty Weight: 350 lbs.
 Filled Weight: 809 lbs.

Features:

- ▶ Inside finish is white enamel
- ▶ Cast Iron imperial feet available
- ▶ Tub exterior available in white (epoxy)
- ▶ 7" centers on the long side of tub
- ▶ ICC-ES certified
- ▶ UPC certified
- ▶ Pre-drilled overflow hole
- ▶ Feet are attached and leveled before shipment
- ▶ Tub is thoroughly inspected before shipment



Foot Finishes:

- BK** Black
- PB** Polished Brass
- CP** Polished Chrome
- WH** White
- PN** Polished Nickel

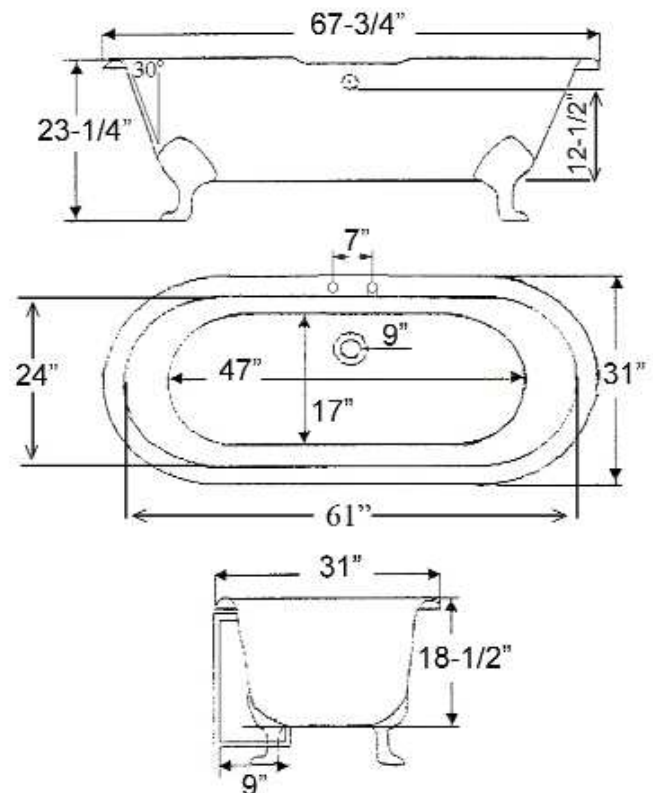

Dimensions and specifications subject to change without notice.

8/22/22

www.rejuvenation.com