

Willamette Sconce

installation instructions

Fixture Installation

1. The fixture will arrive in 2 pieces; the main sconce, the glass shade (packaged separately).
2. Remove crossbar from the canopy and attach crossbar to electrical box.
NOTE: Ensure long flanges are vertical and short flanges are horizontal.
3. Make wiring connections in accordance with local electrical codes.
4. Feed wires through center hole of crossbar and into the electrical box
5. Slip the canopy over the crossbar aligning the holes in the canopy with the holes on the short flanges.
6. Insert a mounting screw into each side and tighten canopy to crossbar.

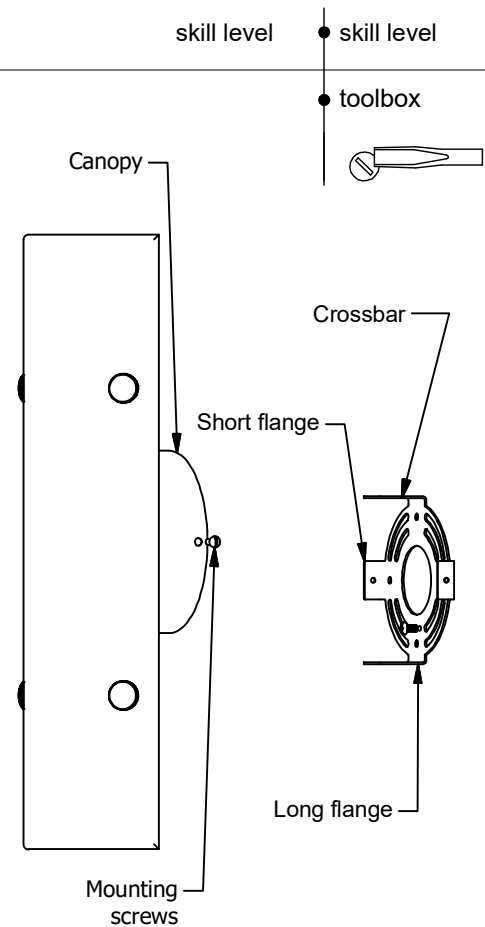

Shade Installation

NOTE: The glass is handmade so the mounting holes in the glass may not align completely with the mounting bracket. The glass is held to the fixture by screwing the four knurled bolts through the holes in the glass and into the mounting bracket.

1. Remove the four knurled bolts and rubber washers from the sconce.
2. Use a combination of the provided rubber washers to space the glass so the knurled bolt can thread into the mounting bracket. If possible, use one rubber washer on each side of the glass.
NOTE: If you ordered fluted glass, it is suggested to use one thin washer on each side of the glass. If you ordered diamond glass, it is suggested to use a thin washer on the outside and a thick washer on the inside surface of the glass.

3. Repeat with all 4 mounting holes.

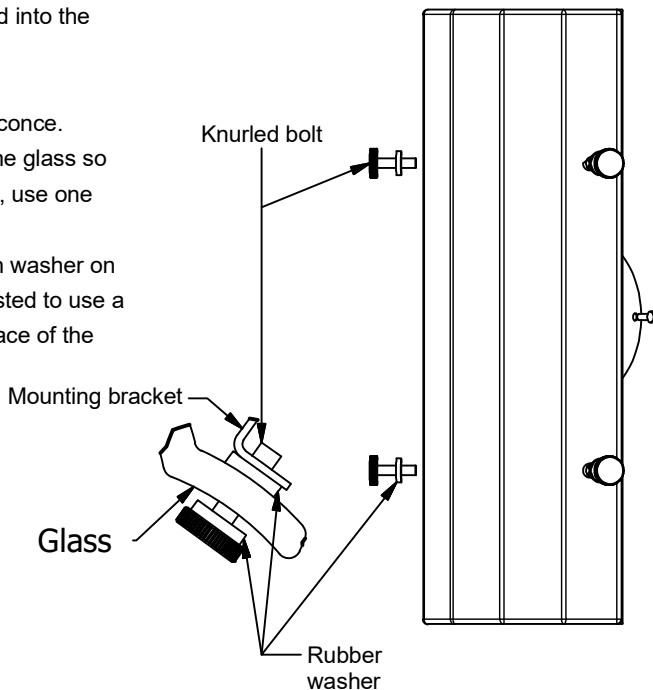

REJUVENATION

2550 N.W. Nicolai Street, Portland Oregon 97210 Customer Service: 888-401-1900 rejuvenation.com